

**APEX
SLIDING DOOR
INSTALLATION
INSTRUCTIONS**

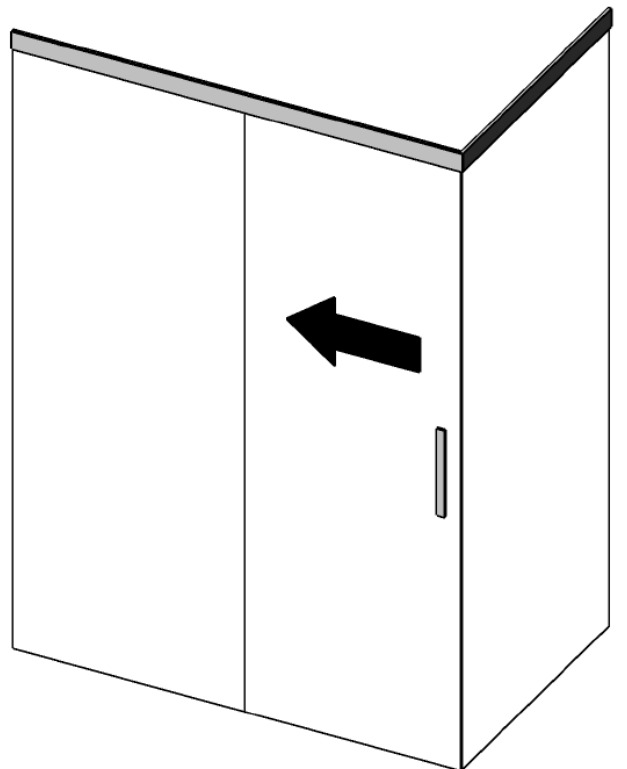

APEX SLIDING DOOR INSTALLATION INSTRUCTIONS

NOTE: Read and understand all instructions before installing shower.

GENERAL SHOWER INFORMATION

- Due to weight of panels, 2 people may be needed to install shower.
- Walls must be plumb to a 2-3mm tolerance where shower is to be installed.
- Floor must be square to wall.

GLASS SAFETY

- Keep glass standing upright.
- Always sit glass on a padded surface i.e. polystyrene.
- Take extra precautions with edges of glass panels.
- If toughened safety glass hits a hard surface or is hit by a hard object, it may shatter or compromise the integrity of the glass.
- It is recommended that safety gloves and glasses are worn during installation.

APEX SLIDING DOOR / /



PARTS LIST

INCLUDED

1. Glass Panels
2. Channel Extrusion Kits
3. Installation Kit
4. Silicone & Adhesive
5. Hardware
6. Base
7. Leak Control Flange with Easy Clean Waste Kit

NEEDED

1. Caulking Gun
2. Level
3. Drill
4. Screw Driver
5. Spray Bottle with Soapy Water
6. Paper Towels
7. Tape Measure
8. Hack Saw or Drop Saw

APEX SLIDING DOOR INSTALLATION INSTRUCTIONS

IMPORTANT INFORMATION

Please read all instructions and warranty information before beginning installation.

It is assumed that this instruction is being carried out by qualified trades-people.

APEX ORDER OF SHOWER INSTALLATION WITH TILED WALLS

1. Base
2. Gib Lining
3. Water Proofing
4. Tiles
5. Channels
6. Glass
7. Sliding Door Track
8. Door

APEX ORDER OF SHOWER INSTALLATION WITH ACRYLIC LINER

1. Base
2. Gib Lining
3. Acrylic Liner
4. Channels
5. Glass
6. Sliding Door Track
7. Door

APEX SLIDING DOOR INSTALLATION INSTRUCTIONS

crest
showers

APEX TILE OVER BASE - CENTRE WASTE / /

IMPORTANT: If additional adhesive is required, **DO NOT** use solvent based glue.

INSTALLATION INSTRUCTIONS

1. PREPARATION

- Clean and prepare the floor area for the shower base.
- The wall linings **MUST** be installed and fitted right down to the floor before installing the base.
- Fit approved Leak Control Flange outlet into the floor, so it can be connected to the outlet S-Trap or Waste Pipe.

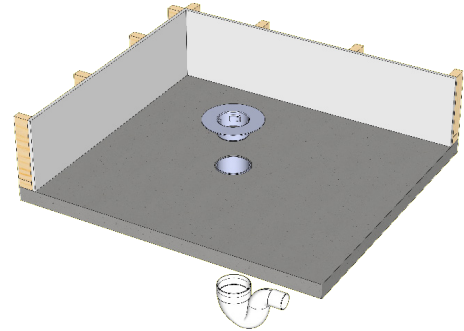

NOTE: Ensure the Waste Trap is unscrewed from Leak Control Flange before installing base.

2. DRY FIT

- Dry fit base into place, making sure the Leak Control Flange and waste hole on the base line up.
- If required, trim edges of waste hole with Stanley Knife to line up with Leak Proof Flange for a smooth transition for Waterproofing Membrane.
- Mark outside of the base with a pencil to set gluing area.
- Check if base is level.

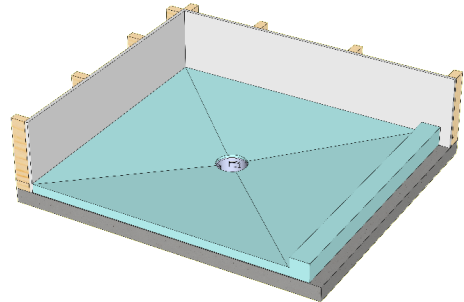

3. GLUING

- Apply recommended adhesive to the marked floor area. Adhesive should be applied in a generous bead (8x8mm) using an evenly spaced parallel pattern - this is to prevent any potential air pockets forming under the base. **ONLY USE SUPPLIED ADHESIVE.**
- If the floor was not level, use extra adhesive or leveling compound to compensate for variation.
- Apply generous bead of adhesive around the top lip of the leak control flange to ensure a good seal.

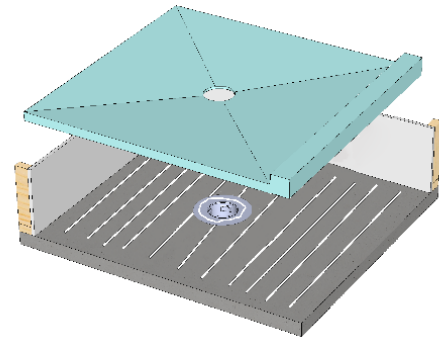

4. FITTING AND CURING

- Fit base back into place and press firmly over the entire surface. Weight the base and check level again before curing.
- Leave weighted for at least 4 hours to ensure adequate adhesion is achieved. Full curing of the adhesive is 24 hours minimum.
- At no stage should the tiling or waterproofing be applied until the base is correctly installed and the Adhesive has cured.

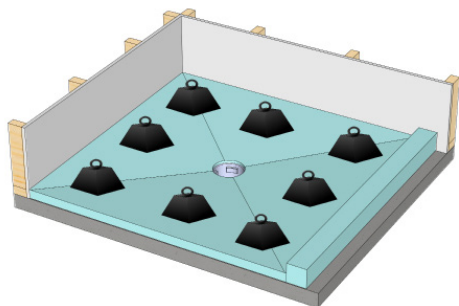

BASE

APEX SLIDING DOOR INSTALLATION INSTRUCTIONS

WATERPROOFING

Once the base is secured to the floor and the glue is cured, the waterproofing membrane can be applied. Most popular, certified waterproofing membranes can be used on an Apex base. If in doubt, your waterproofer or tiler will seek professional advice from their supplier if unsure. All waterproofing must be done by a certified waterproofing specialist.

5. WATER PROOFING

- Apply the Waterproofing Membrane according to the manufacturer's instruction (with correct waterproofing edge, bandages, corners and reinforcing tapes).
- Ensure Waterproofing is applied to walls from the top of the shower line, down the base and out across the base, into the leak control flange to the top of the threads.
- Ensure the Waterproofing returns up the inside vertical face of the edge hobs, across the top edge, down the floor line and on the outside of the tile over shower base. (Note your council may require the remaining bathroom floor to be waterproofed also).
- Ensure waterproofing is applied well down into the Leak Control Flange, to the top of the thread line.

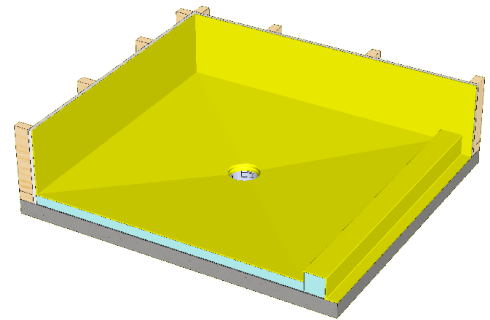

6. CENTRE WASTE

- Re-screw Waste Trap back into Leak Control Flange.
- Tiler will use the threaded height adjustment screw to position the lid to align slightly below the finished tile height.

APEX SLIDING DOOR INSTALLATION INSTRUCTIONS

crest
showers

APEX TILE OVER BASE - CHANNEL WASTE / /

INSTALLATION INSTRUCTIONS

1. PREPARATION

- Clean and prepare the floor area for the shower base.
- The wall linings MUST be installed and fitted right down to the floor before installing the base.
- Fit Leak Control Flange Outlet into the floor, so it can be connected to the outlet S-Trap or Waste Pipe. The Leak Control Flange may need to be trimmed if the Channel Waste is positioned close to the end of the wall.

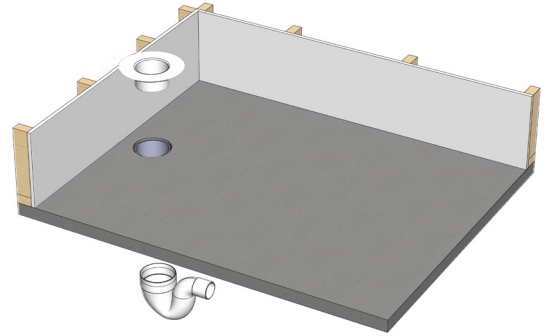

2. DRY FIT

- Dry fit base into place, making sure the Leak Control Flange and waste hole on the base line up.
- If required, trim edges of waste hole with Stanley Knife to line up with Leak Control Flange for a smooth transition for Waterproofing Membrane.
- Mark outside of the base with a pencil to set gluing area.
- Check if base is level.

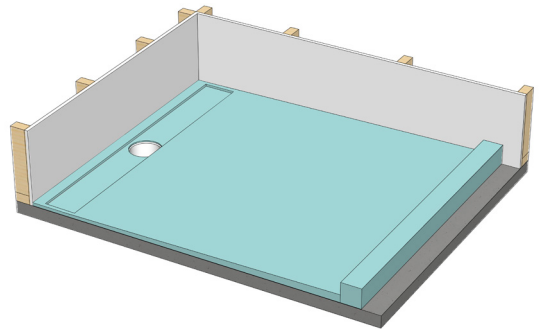

3. GLUING

- Apply recommended glue to the marked floor area. Glue should be applied in a generous bead (8x8mm) using an evenly spaced parallel pattern - this is to prevent any potential air pockets forming under the base.
- If the floor was not level, use extra adhesive or leveling compound to compensate for variation.
- Apply generous bead of adhesive around the top lip of the leak control flange to ensure a good seal.

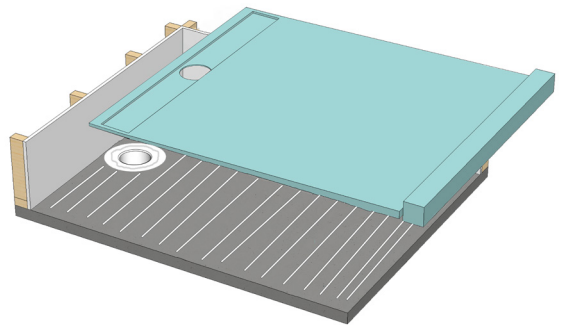

4. FITTING AND CURING

- Fit base back into place and press firmly over the entire surface. Weight the base and check level again before curing.
- Leave weighted for at least 4 hours to ensure adequate adhesion is achieved. Full curing of the adhesive is 24 hours minimum. At no stage should the tiling or waterproofing be applied until the base is correctly installed and the adhesive has cured.

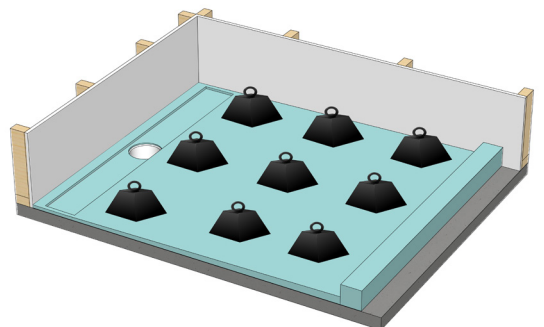

APEX SLIDING DOOR INSTALLATION INSTRUCTIONS

crest
showers

WATERPROOFING

Once the base is secured to the floor and the glue is cured, the Waterproofing Membrane can be applied. Most popular, certified Waterproofing Membranes can be used on an Apex base. If in doubt, your waterproofer or tiler will seek professional advice from their supplier if unsure. All waterproofing must be done by a certified waterproofing specialist.

5. WATER PROOFING

- Apply the waterproofing membrane according to the manufacturer's instruction (with correct waterproofing edge, bandages, corners and reinforcing tapes).
- Ensure waterproofing is applied to walls from the top of the shower line, down the base and out across the base.
- Ensure the waterproofing returns up the inside vertical face of the edge sill's, across the top edge, down the floor line and on the outside of the tile over shower base. (Note your council may require the remaining bathroom floor to be waterproofed also).
- Ensure waterproofing is applied well down into the leak control flange/puddle flange.

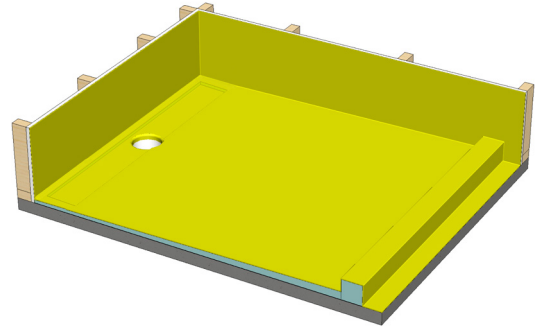

6. CHANNEL WASTE

- Once the water proofing has cured, the tiler will need to set up the height of the channel waste drain lid to align with the finished surface of the selected tiles. This is achieved by applying large 'daubs' of adhesive under the channel drain to set the finished channel drain height. This is to allow any leakage of water beneath the tiles to be able to work it's way out towards the waste outlet under the channel drain. (A solid mass of adhesive will only trap any water around the channel drain and potentially cause pooling of water.)
- Position the channel drain on the daubs of adhesive and check the final height is set below the finished tile height. Ensure a 15-20mm clearance is around all sides of the channel drain to accommodate for wall tiles so the removable lid is able to be removed for cleaning.

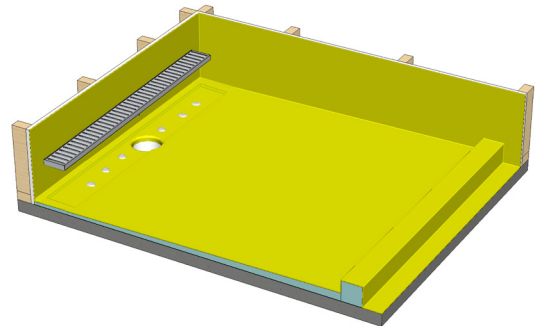

APEX SLIDING DOOR INSTALLATION INSTRUCTIONS

7. TILING

Ensure tiling is done before the channels are installed.

8. INSTALLING GLAZING CHANNELS

- Use a 2 meter level to check walls are within 2-3mm of plumb.
- Using measurements on dimension sheet, mark out channel positions on floor tiles. Set out floor channels and check shower entry space dimensions are correct.
- Clean tiled floor and underside of channel with a dry rag. Run a thick bead of silicone along underside of floor channel (FIG 1).
- Place floor channel in position and press downwards. Remove plastic from stabilizer blocks and stick to base either side of channel to keep in place (FIG 2).
- Slide wall channel on top of floor channel, making sure they butt up to each other and insert channel connector inside 'wall to floor' join to help line up the wall channel (FIG 3).
- When plumb, drill 2 holes (3.5mmD) in wall channel, lining up with framing locations. (FIG 4). The top hole should be within 100mm of top of channel and the second hole within 1000mm of top of channel. No screws will be required lower than 1000mm up from the floor.
- Remove dust from holes and from inside floor channel. Clean underside of wall channel with a dry rag before running a thick bead (be very liberal to allow overflow and proper adhesion) of silicone in a continuous line down the entire length of the back of the wall channel (FIG 1) and place on wall.
- Inject silicone into and around screw holes (FIG 4). Ensure wall channel is plumb, then screw in place.
- Pop out channel connector and apply silicon into the floor to wall junction, placing the channel connector back in once done.

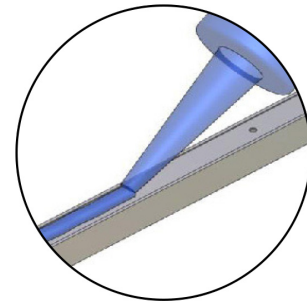

FIG 1.



FIG 2.



FIG 3.

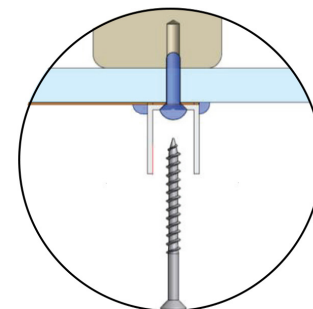

FIG 4.

IMPORTANT

As an added waterproofing precaution, you can apply a continuous bead of silicon down the whole length of wall channel either on the interior or exterior of the wall channel as at your discretion.

APEX SLIDING DOOR INSTALLATION INSTRUCTIONS

IMPORTANT: We highly recommend dry fitting fixed panels prior to installation to ensure exact measurements of required sliding door gap is achieved as pictured in supplied dimension sheet. Ensure all fixed panels are plumb and level. Use setting blocks as required to achieve this.

CORNER SLIDING DOOR / /

9. INSTALLING PANELS

- Clean inside of channel with a dry rag. Place 8mm setting blocks in bottom of floor channel (2-3 per panel). Glass must always be resting on setting blocks not straight onto channel.
- When panels are correctly aligned, remove panel 1 (FIG 5) and run a thick continuous line of silicone down the inside of the wall channel (FIG 6) and apply liberally in the wall to floor channel join and along the floor channel to the length of the glass panel.
- From outside the shower, slide glass panel into position (FIG 7) and use small wedges (FIG 8) or a flat plastering blade to slide glass panel back to inside edge of channel and against silicone.
- Ensure panel is still level and plumb.

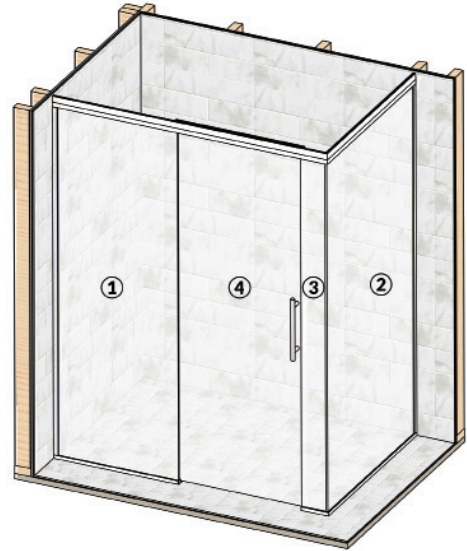

FIG 5.

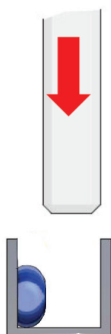

FIG 6.

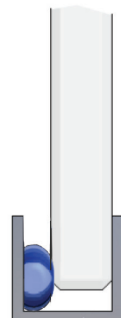

FIG 7.

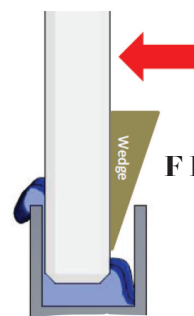

FIG 8.

APEX SLIDING DOOR INSTALLATION INSTRUCTIONS

10. FINISHING GLAZING CHANNEL TO GLASS PANEL JOIN

- Starting at the top of the wall channel, from outside shower, spray with warm soapy water then insert rubber wedge seal into gap (removing plastic wedges if used). (FIG 9) Leave rubber wedge protruding 40mm at top to cut off later.

IMPORTANT: Rubber wedge must be pressed into channel lightly from top to bottom before pushing right in. This method ensures rubber wedge does not set stretched and then shrink later.

- Repeat steps 3 and 4 with applicable panels.

FOR GLASS TO GLASS JOINS:

- Apply masking tape down the length of the panel, allowing a 10mm gap for the glass to butt into for the glass to glass join (FIG 10).
- Run a continuous bead of silicon down entire length of 10mm face of installed wall to glass panel and across floor channel to the width of the glass to glass panel (FIG 11).
- Gently place glass to glass panel into siliconed floor channel and tilt gently upwards until it joins to glass to wall panel (FIG 12). Ensure there is no side to side movement while placing panel as this will smear silicone.
- Hold glass to glass join in place with masking tape.

- Cut off excess rubber wedge.
- Spray channels and glass with slightly soapy water then use spatula provided to clean off excess silicone (FIG 13). Repeat this process 3 times. Use minimal water then wipe off with paper towels.

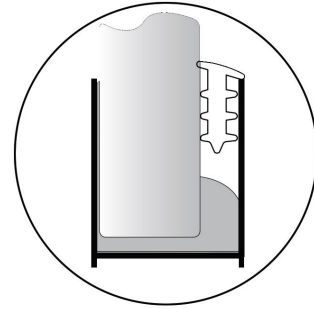

FIG 9.

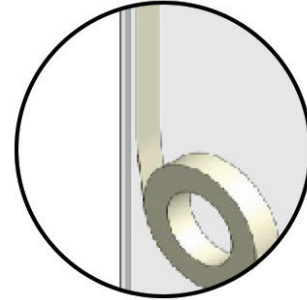

FIG 10.

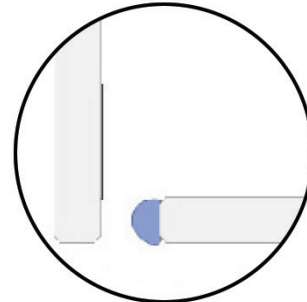

FIG 11.

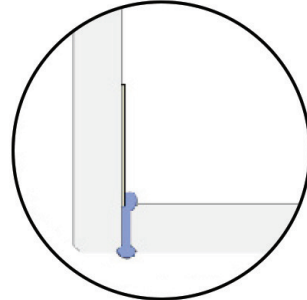

FIG 12.

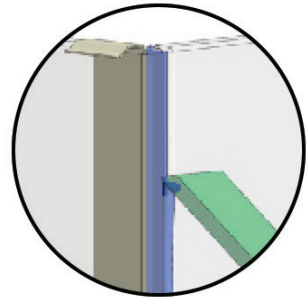

FIG 13.

APEX SLIDING DOOR INSTALLATION INSTRUCTIONS

IMPORTANT

- Check the length of the sliding door track once the fixed panels are installed plumb and level. If necessary, you may need to trim (the square cut end) in order to obtain the exact correct length.
- Place the glass sliding door (still in its packaging) inside the shower cubicle and out of the way before fitting the sliding door track.

11. DRY FITTING SLIDING DOOR TRACK

- With corner showers, use the grey corner block in the mitred corner (FIG 14) to support the join. This should press into the mitred corner, and be a tight snug fit.
- Once corner mitre has been fitted together, neatly drill 2 x 3.5mm locating holes down through the top of the sliding door track (in the centre of the rebated slot) and 3.0mm pilot holes (30mm deep) into the nylon corner block (FIG 15).
- Screw in the self-tapper screws supplied. This will hold and lock the corner mitre block together.
- Carefully bruise the sharp corner of the mitre with a rounded screwdriver shaft or similar to remove the sharp edge of the external corner.

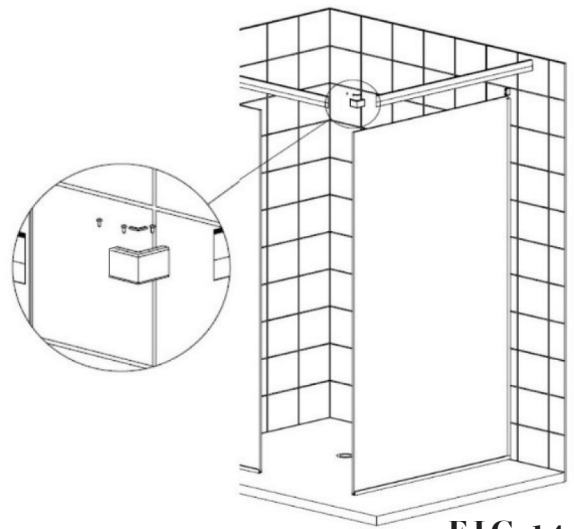

FIG 14.

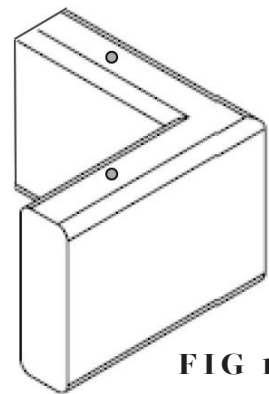

FIG 15.

12. FIT SLIDING DOOR GUIDE

- Place bottom door guide into end of fixed panel floor channel, pressing firmly into place (FIG 16). No screws are required though a small amount of silicone may be used if desired.

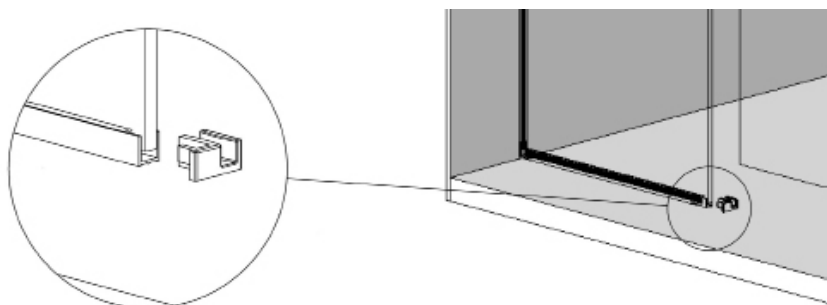
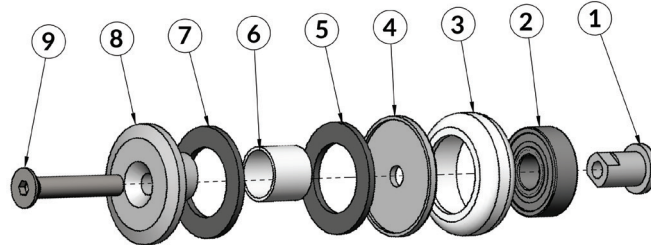

FIG 16.

APEX SLIDING DOOR INSTALLATION INSTRUCTIONS

IMPORTANT

- The roller components will be supplied as a single assembled piece. Separate parts 1-3 (keeping them together as an entire component) from the assembly. These parts will be slid into the sliding door track.



13. INSERT STOP BLOCKS, WHEELS & WALL ANCHOR BLOCK

- Slide the components into the sliding door track in the following order:

CORNER SHOWER

DOOR SIDE

1. Stop Block
2. Wheel
3. Wheel
4. Stop Block
5. Wall Anchor

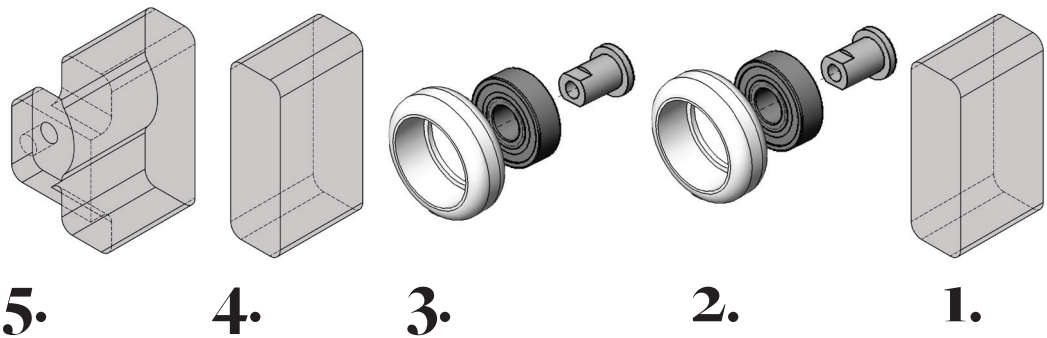

RETURN PANEL SIDE

1. Wall Anchor

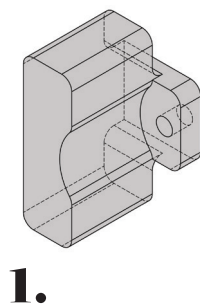

ALCOVE SHOWER

1. Wall Anchor
2. Stop Block
3. Wheel
4. Wheel
5. Stop Block
6. Wall Anchor

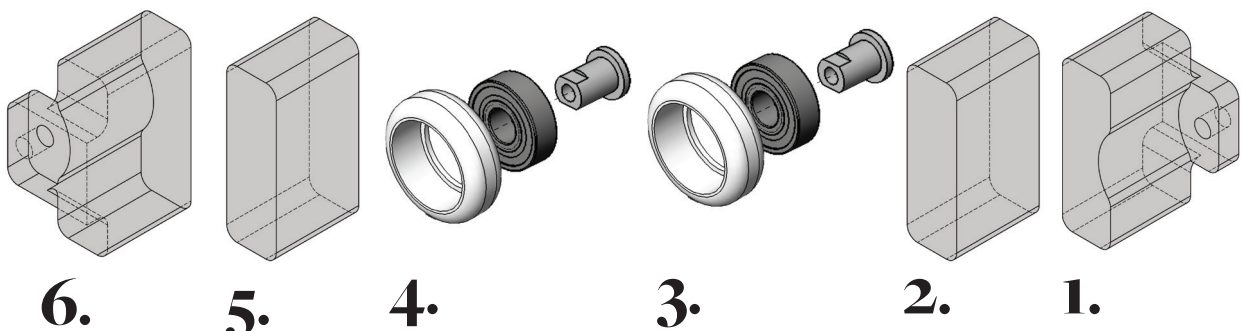

APEX SLIDING DOOR INSTALLATION INSTRUCTIONS

14. FITTING THE SLIDING DOOR TRACK ON TOP OF THE FIXED GLASS PANELS

- Use 2mm setting blocks on top of fixed glass panels to prevent the sliding door track metal directly contacting the glass (FIG 17). Dry fit and position on top of glass.
- Double check the sliding door track is level. Adjust with setting blocks if necessary.
- When you are confident the track fits neatly and correctly in place, remove sliding door track and place a generous bead of silicone in the underside groove of the sliding door track (FIG 18). **DO NOT PUT THE SILICONE BEAD ABOVE THE DOORWAY.**
- Carefully refit the sliding door track with the silicone in the groove back onto the top of the glass panels.
- Press down and position the sliding door track into place. Check for level and support if needed with wooden setting blocks while the silicone sets.
- Clean off any silicone with soapy water from a spray bottle then scrape off the surplus silicone with the spatula. Repeat this procedure again until all the silicone has been removed and cleaned off glass.

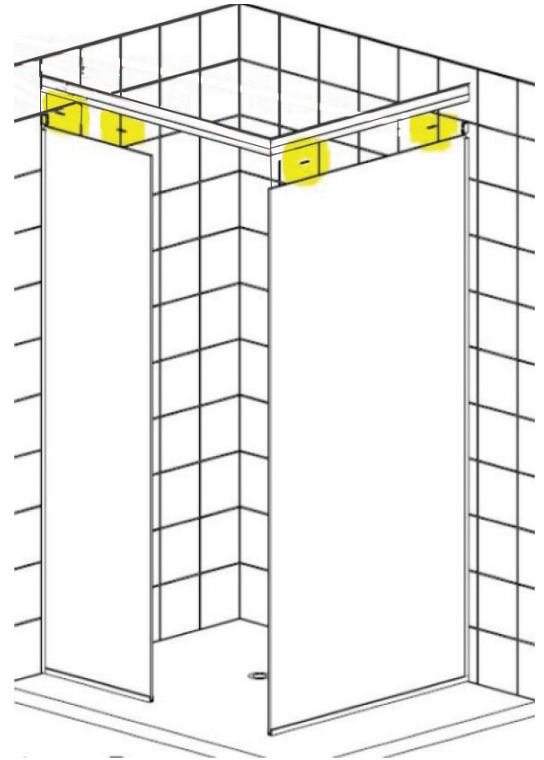

FIG 17.

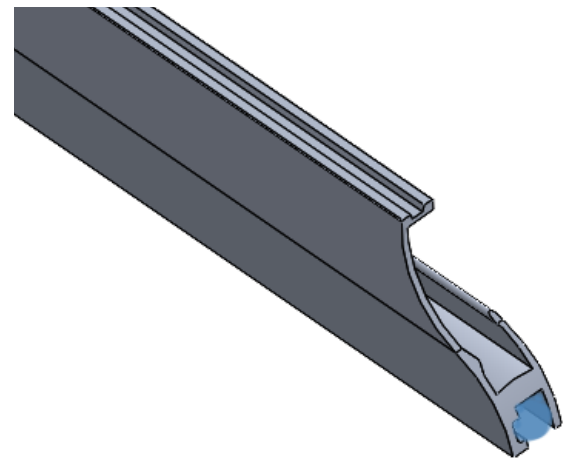

FIG 18.

15. SECURE THE WALL ANCHOR BLOCKS

- Once the sliding door track has been fitted and held in place, the wall anchor blocks can be moved into position towards the wall (FIG 19).
- Carefully drill and screw 1 x 6 gauge stainless screw through the pre-holed tab and into the wall. As this is only taking side load (i.e. no tension load pulling the screw out) it is not imperative to have this screwing into solid wall fixing/nogging.
- Once the pilot hole for the screw has been drilled, fill the hole with silicone in order to seal off the hole.

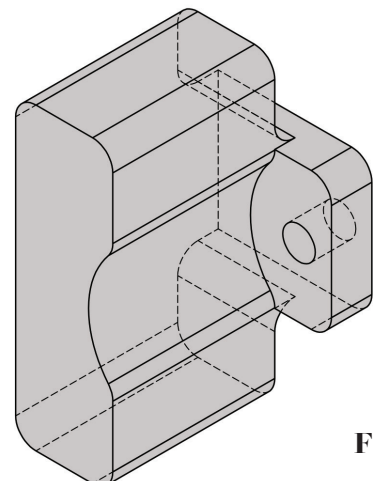

FIG 19.

APEX SLIDING DOOR INSTALLATION INSTRUCTIONS

16. FITTING THE DOOR ROLLERS ONTO THE GLASS

- Separate parts 4 through 6 (bush) from parts 7 through 9 (hub) (FIG 20).
- Unwrap door and place in correct position.
- With the bush and hub pre-assembly in the opposite sides of the holes (FIG 21), place the glass sliding door into position on the wooden wedges, aligning the roller wheel holes at the top of the door as close as possible to align with the rollers in track.
- Using the wooden wedges to raise and lower the door.
- Use the allen key to engage and screw in the bolt (9, FIG 20).

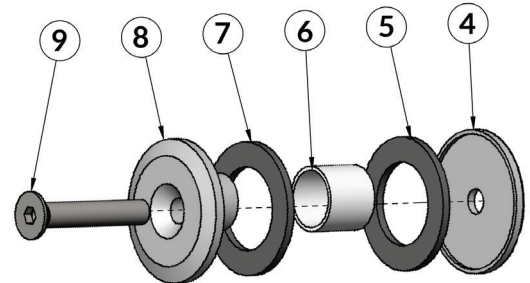
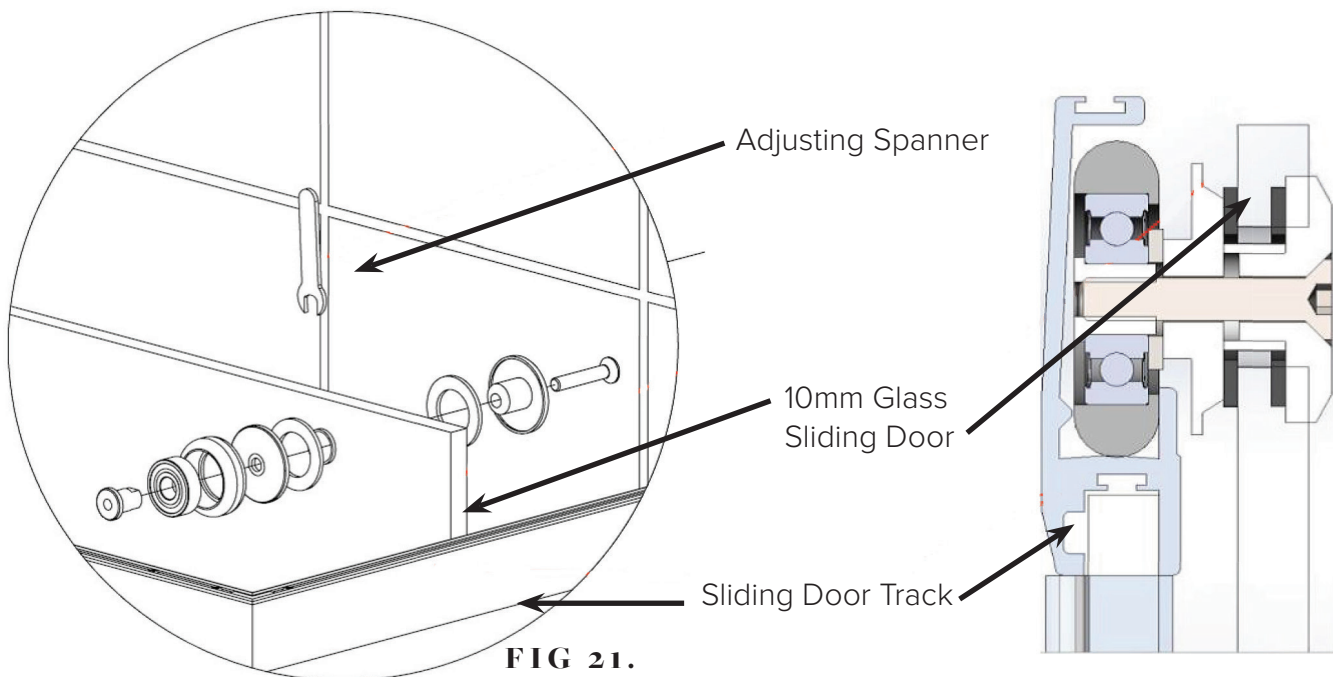

FIG 20.



- Make sure the nylon washers are flat against the glass so no metal contacts the glass (5 & 7, FIG 20).
- Ensure the nylon bush is located correctly inside the hole to protect the glass from contacting the axle bolt.
- Slowly tighten the countersunk hex bolt and the wheel together and gently lock the assembly together so it is taking the weight of the door on the rollers.

APEX SLIDING DOOR INSTALLATION INSTRUCTIONS

17. ADJUSTING THE HEIGHT OF THE DOOR

- Use the small spanner supplied to fit between the glass door and the track and onto the axle to hold or turn the offset hub to adjust the height of the door.
- By rotating the spanner and the set screw axle together, the door will lift or lower by up to 10mm.
- Ensure the vertical door faces line up and are parallel with the return or fixed panels.
- Once the door is set at the desired height to pass over the door guide at the bottom of the door, hold the axle with the spanner and do a final good strong tightening of the countersunk hex head bolt to lock the axle roller wheels into position.

18. FITTING DOOR HANDLE

- Remove the handle from the wrapper, dismantle and re-assemble onto either side of the door. Take care to ensure the plastic bushes are located inside the locator holes and the locking hex screws are tightened so the handle is tight and secure (FIG 22).

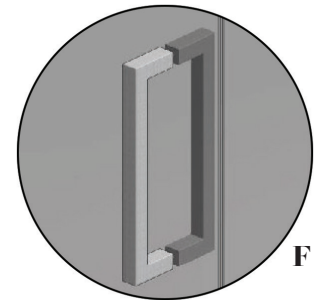

FIG 22.

19. SETTING DOOR STOP BLOCKS

- Carefully move door to the open position (5-10mm before door handle strikes the glass) and slide along the plastic door stop up against the back wheel. Screw down through the top of the track (FIG 23).
- Repeat this for the closed position.
- Add PVC door seal to vertical face of door so the glass does not strike on the return glass panel.
- Check that the door does not strike in any position glass against glass, glass against metal handle or glass against wall.
- Before opening and closing the door too many times, use a damp cloth or similar to clean out any filings, swarf or debris on the inside of the sliding door track where the door rollers will be running. If this is not cleaned, the door or rollers will not run smoothly.

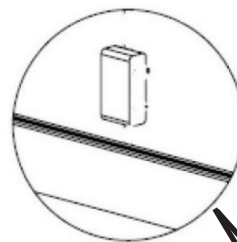
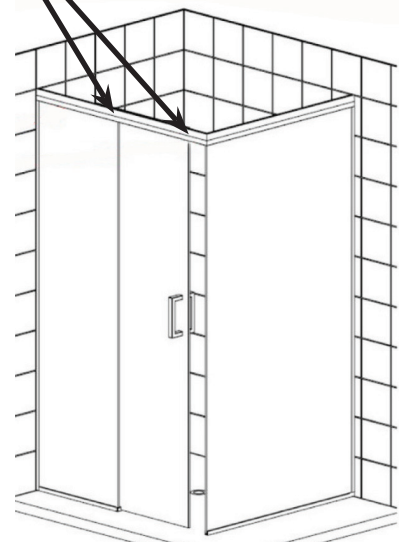

FIG 23.



21. COMMISSIONING SHOWER

NOTE: Clean glass and ensure no silicone residue remains on glass, channel or surrounding area.

22. CARE AND MAINTENANCE

You can keep your Apex shower looking it's very best by following a few simple guidelines:

- Clean shower twice weekly using a mild detergent in warm water and a soft lint free cloth. Ensure channels, hinges and handle are properly cleaned.
- A quick wipe down with a shower squeegee after each use will prohibit water staining the glass.
- Do not use abrasive cleaners or high strength chemicals on your shower.
- On sliding doors, occasionally check the inside of the sliding door channel track and wipe out or remove any debris or items that may have become trapped in the channel.

23. APEX WARRANTY

Crest Shower Systems warrants that when installed as per the supplied instructions, the Sereno Shower System will be free from manufacturing defects for a period of 10 years from the date of sale. This means that apart from the typical surface splash, no water will be allowed to leak into the building structure for a minimum of 10 years.

All products supplied by Crest Shower Systems exceed the requirements of the New Zealand Building Code and all glass is manufactured to meet AS/NZS2208 1996 Grade A Safety Glass and is permanently marked as such in accordance with the code.

Crest Shower Systems will supply replacement parts or product at its discretion, free of charge where product is covered by this warranty and proof of defect has been received within 100 days of first appearance. To ensure warranty remains valid, the supplied care and maintenance instructions must be adhered to and the Crest Warranty form supplied with the product must be complete and returned at time of purchase (hard copy or Online). Warranty is non-transferable.

Crest will be liable for the replacement of products or components including their installation, or for an equivalent product including its installation, should the supplied product or component be declared defective by an authorised Crest Shower Systems representative. Beyond this, Crest will not be liable for any damages including incidental or consequential damages related to the use of this product.

Warranty does not apply to the following situations:

- Shower has been improperly installed.
- Shower has been misused or damaged.
- Shower damaged or defective prior to installation.
- Supplied instructions were not adhered to during installation. Note: Discretion must have been used at all times by installer as each situation may vary.

INSTALLATION WARRANTY

Your approved Crest shower installer should provide you with a written 5 year minimum installation workmanship warranty. Product warranty applies regardless of who has installed the shower.

W A R N I N G

This Apex Shower has just been installed.

PLEASE DO NOT WORK IN OR AROUND THE SHOWER UNTIL



Any queries feel free to ring me on:



**Best Regards
Your Shower Installer**

crest
showers

CREST SHOWER SYSTEMS

W: www.crestshowers.co.nz

E: sales@crestshowers.co.nz

P: 0800 40 40 42